

Optimization of PID - Capacitive Energy Storage for Load Frequency Control in Two Area Interconnected Power System Using Quantum Behaved PSO

by Ys Akil

Submission date: 15-May-2023 06:54PM (UTC+0700)

Submission ID: 2093674277

File name: EPI040_Pressa_Perdana-ok.pdf (497.51K)

Word count: 3038

Character count: 14456

Optimization of PID - Capacitive Energy Storage for Load Frequency Control in Two Area Interconnected Power System Using Quantum Behaved PSO

Pressa Perdana Surya Saputra^{1,a)}, Yusri Syam Akil^{2,b)}, Efta Dhartikasari^{1,c)}, and Kukuh Widarsono^{3,d)}

¹Electrical Engineering, Universitas Muhammadiyah Gresik, Gresik, Indonesia

²Electrical Engineering Department, Hasanuddin University, Gowa, Indonesia

³Electrical Engineering, State Polytechnic of Madura, Surabaya, Indonesia

^{a)}Corresponding author: pressa@umg.ac.id

^{b)}yusakil@unhas.ac.id

^{c)}eftadhartikasari@umg.ac.id

^{d)}kukuh.widarsono@gmail.com

Abstract. This study presents the solution to the frequency oscillation problem in Two area interconnected power system using the PSO and Quantum Behaved PSO (QPSO) methods. These two methods are used to tune the parameters on the PID and CES (Capacitive Energy Storage) in Two area interconnected power system. The simulation is done by comparing the system frequency response with PID, system frequency response with PID-CES with manual parameter tuning, and system frequency response with PID-CES optimized using PSO and QPSO. The simulation result shows that using the PSO and QPSO applications to set parameters on the PID-CES can reduce overshoot and accelerate the settling time of frequency and power oscillations in Two area interconnected power system. Optimization with PSO resulted in an overshoot of -0.00183 p.u. in Area 1, -0.00053 p.u. in Area 2 and -0.00092 p.u. in Two area. Meanwhile, optimization with QPSO results in an overshoot of -0.00207 p.u. in Area 1, -0.00088 p.u. in Area 2 and -0.00165 p.u. in Two area. The final results show that in case of Two area power system, PSO can reduce oscillations better than QPSO, but it produces ripple. Meanwhile, the QPSO optimized system produces smoother and has no ripple responses.

INTRODUCTION

Electricity is one of the most important needs in human life. The increasing demand for electric power causes an increase in the electric power supplied by the generator. Changes in electrical power can disrupt system stability. So that system stability is included as part of the quality of the electric power system [1].

Unexpected load changes can cause voltage and frequency oscillations in the generator. This phenomenon can reduce the quality of electricity delivered to consumers. Oscillation in electric power systems can be suppressed by using electrical energy storage devices [2,3]. This equipment can assist the rotor's ability to adjust rotation to the loading conditions. The use of Magnetic Energy Superconducting Storage (SMES) and Battery Energy Storage to improve the dynamic performance of electric power systems has been widely used and has given satisfactory results [4,5,6]. However, the application of these two tools in the electricity system actually has several disadvantages in terms of maintenance and costs.

Capacitive Energy Storage (CES) can be an alternative option to reduce oscillations in electric power systems. In practical application, CES does not require operational costs and also does not have a negative impact on the environment [7]. The operation of CES is also quite simple and cheaper when compared to SMES. SMES requires a liquid helium cooling system during operation, but CES does not [7].

Optimization methods that commonly used for power system include such as are Genetic Algorithm (GA), Particle Swarm Optimization (PSO), and Ant Colony Optimization (ACO) [8,9,10]. This study presents the results of optimization using PSO and the development of PSO, namely QPSO to optimize PID and CES parameters in Two area interconnected power system in order to obtain reliable control coordination in reducing oscillations in electric power system.

MODELLING SYSTEM

LFC Modeling in Two Area Electric Power System

In a multi area electric power system, generators are connected as one (interconnection), all machines work synchronously so that they must operate at the same frequency [11,12]. Changes in load can cause dynamic disturbances. This causes frequency oscillation to occur in the generator. In a multi area electric power system, big changes in load can cause the generator to become out of synchronous. Therefore, we need a load and frequency regulation called Load Frequency Control (LFC) [18]. This is done by adjusting the response of the governor of each area.

In this study, system data from [11] for LFC model of the Two area power system were used. The system model can be seen in Fig. 1 and the system parameters are shown in Table 1.

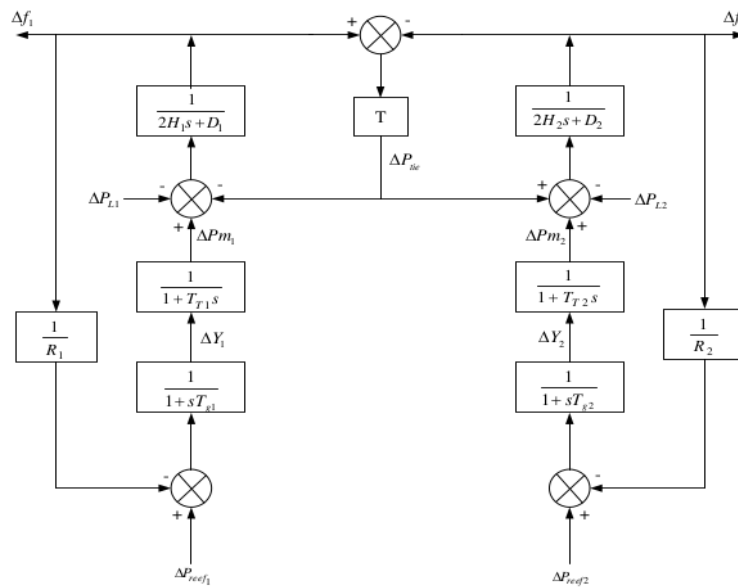

FIGURE 1. LFC System Two Area [11]

TABLE 1. System parameters [11]

	Area 1	Area 2
Speed Drop (R)	0.05	0.0625
Damping Constant (D)	0.6	0.9
Inertia Constant (H)	5	4
Base Power (MVA)	1000	1000
Governor Time Constant (T _g)	0.2	0.3
Turbine Time Constant (T _t)	0.5	0.6

In the system simulation in Area 1, one cases of disturbance were given, namely changes in the load of 0.1 p.u. A change in load in Area 1 will result in the system in Area 2 being disrupted, this is because all areas are interconnected. After that, we observed the change in frequency (Δf) for each area and the power between the Ptie areas.

CES Modeling in Two Area Electric Power System

CES is a device that can store and release large amounts of power simultaneously. The purpose of using CES is to reduce power frequency oscillations in a power system [13]. A CES consists of a storage capacitor and a Power Conversion System (PCS) with control and safety functions. The configuration of the CES is shown by Fig. 2. From Fig. 2 it can be seen that the storage capacitor is connected to the AC grid via a power conversion system consisting of an inverter / rectifier. This storage consists of several capacitors connected in parallel, with a lumped capacitance 'C'. The leakage losses and dielectric capacitor bank for CES are modelled by the resistance R parallel to the capacitor [13]. The process of operating in and out current, at CES is controlled by applying the correct voltage to the capacitor. The applied voltage is controlled by controlling the ignition angle on the converter bridge [2,13]. The linear model of the CES is shown in Fig. 3.

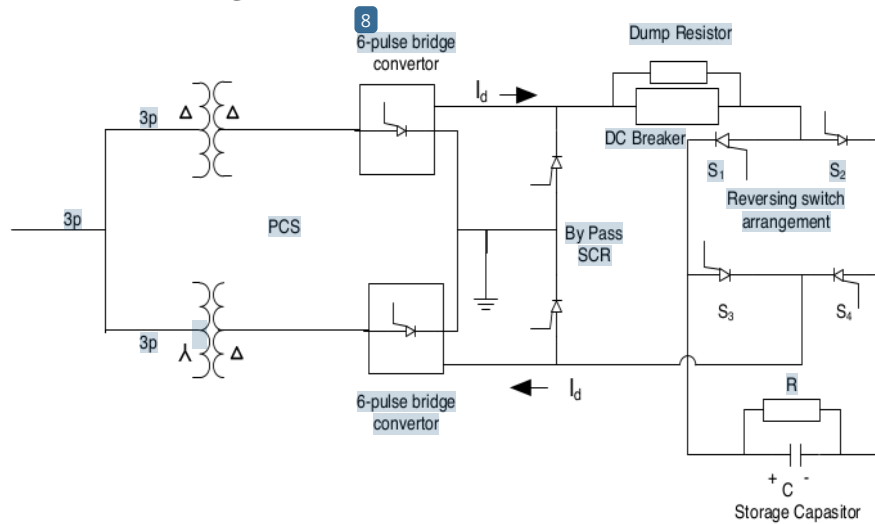

FIGURE 2. Capacitive energy storage

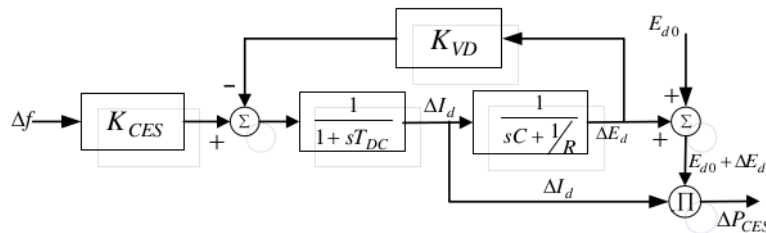

FIGURE 3. Capacitive energy storage block diagram

Systems with PID controllers will be added with CES. CES adjusts the frequency change signal for each area (Δf). The output from CES is the power that is injected into the system. CES installed in each area. A sample of system with PID and CES controllers in Two area system can be seen in Fig. 4. The CES data are in Table 2.

TABLE 2. CES parameter data

CES Parameter	Value
K_{CES}	70
K_{VD}	0.1
T_{dc}	0.05
C	1
T_{dc}	0.026
R	100
E_{d0}	0.5

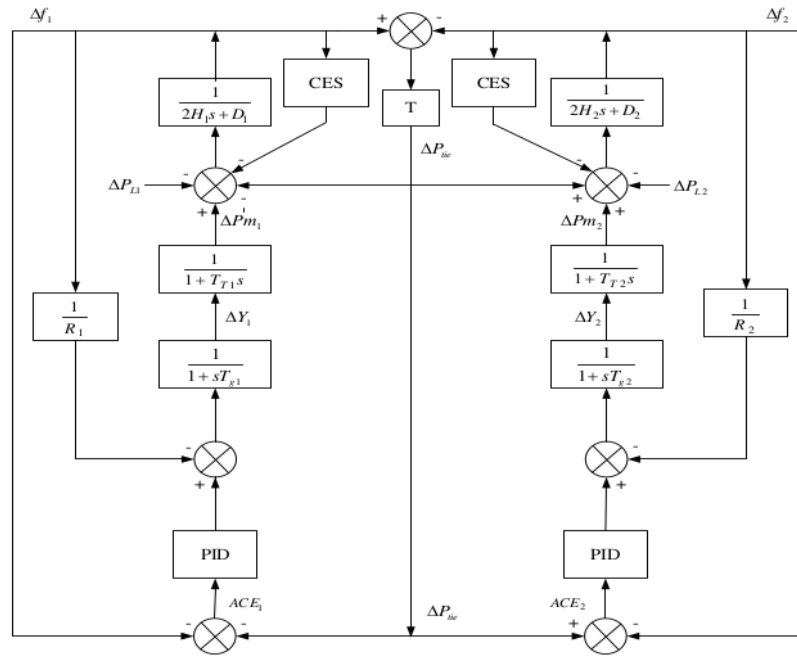

FIGURE 4. Systems with PID and CES controllers

QUANTUM BEHAVED PSO (QPSO)

20

In 1995, PSO is introduced by Kennedy and Eberhart [14]. This algorithm has several advantages, such as simple, easy in implementation, and has been successfully used to solve various optimization problems [15,16]. By mimicking the behaviour of a group of birds and fish in search of food, the optimal value is searched by PSO. A group or population of the birds and fish are called swarm. While each individual of bird and fish are called particle. Furthermore, there has been a significant development of the PSO method, e.g. QPSO. QPSO is a method that provides an innovation to the position function of particles dispersed in the PSO method. The difference between them lies in the nature of the position function being used.

QPSO is an integration between quantum computing and PSO. In PSO, the particle state is characterized by position and speed functions. Meanwhile, in QPSO, the particle state is characterized by the wave function $\Psi(x,t)$. $|\Psi(x,t)|^2$ is the position's probability density function. Weaknesses in the standard PSO are tend to achieve convergence in local optima and cannot guarantee global convergence [17]. To overcome this problem, QPSO can be

used which can guarantee global convergence. By applying the Monte Carlo method, the position update function of each particle in the QPSO is written in Equations 1 and 2 as follows [18,19].

$$X_{id}(t+1) = p_{id}(t) + \beta(t) \times (mbest_d(t) - X_{id}(t)) \times \ln\left(\frac{1}{u}\right) \text{ if } k \geq 0.5 \quad (1)$$

$$X_{id}(t+1) = p_{id}(t) - \beta(t) \times (mbest_d(t) - X_{id}(t)) \times \ln\left(\frac{1}{u}\right) \text{ if } k < 0.5 \quad (2)$$

$$p_{id}(t) = \varphi_d(t) \times pbest_{id}(t) + (1 - \varphi_d(t)) \times gbest_d(t) \quad (3)$$

$$\varphi_d(t) = \frac{c_1 \times r_{1d}(t)}{(c_1 \times r_{1d}(t)) + (c_2 \times r_{2d}(t))} \quad (4)$$

$$mbest_d(t) = \frac{1}{N} \sum_{i=1}^N pbest_{id}(t) \quad (5)$$

where,

t	= Iteration
$X_{id}(t)$	= Position of "i" particle in "d" dimension when "t" iteration
$X_{id}(t+1)$	= Position of "i" particle in "d" dimension when "t+1" iteration
$p_{id}(t)$	= local attractor
c_1	= Acceleration constant 1 (cognitif constant)
c_2	= Acceleration constant 2 (social constant)
$r_{1d}(t)$	= Random number between 0-1 when "t" iteration
$r_{2d}(t)$	= Random number between 0-1 when "t" iteration
N	= Number of particles
$pbest_{id}(t)$	= Local best position
$gbest_d(t)$	= Global best position
$mbest_d(t)$	= Mean value of local best position

Another parameter known in the QPSO algorithm is the contraction-expansion coefficient. This parameter is used to adjust the convergence speed of the particles. A higher initial beta value can give greater population diversity, whereas at a later stage a lower beta value makes exploration more focused on space search. The initial value β_{max} is used to accommodate more global initial searches and decreases to β_{min} . It aims to end the QPSO algorithm with better local search. The contraction expansion coefficient (beta) function is written in Equation 6 as follows [20,21]:

$$\beta(t) = \beta_{max} - \left(\frac{\beta_{max} - \beta_{min}}{iter_{max}} \right) \times iter(t) \quad (6)$$

where,

$\beta(t)$	= contraction-expansion coefficient (beta)
β_{max}	= Initial value of contraction-expansion coefficient
β_{min}	= Initial value of contraction-expansion coefficient
$iter_{max}$	= maximum iteration
$iter(t)$	= Iteration

SIMULATION AND ANALYSIS

In the system simulation in Area 1 there is a disturbance, namely a change in load of 0.1 p.u. Simulations are carried out to analyze system responses. The system responses analyzed were changes in Area 1 frequency (Δf_1), changes in Area 2 frequency (Δf_2), and inter-area power (Ptie). The system response with PID and CES which has been optimized using QPSO and PSO is compared with the system with PID and systems with PID and CES. In addition, a simulation was also carried out to determine the effect of the capacitor on CES on the system response.

Figure 5 is the frequency response of Area 1 (Δf_1). It can be seen in Fig. 5 that a system with a PID controller has an overshoot of -0.00358 p.u. and a settling time of 21 seconds. Then after installing the PID and CES, the overshoot decreases to -0.00197 p.u. while the settling time became 19 seconds. While optimization using PSO, the overshoot decreases to -0.00183 p.u. and the settling time became 11.2 seconds. And then optimizing using QPSO, the overshoot increases to -0.00207 p.u. and the settling time became 11.2 seconds. The comparison of the overshoot and settling time of the Area 1 frequency response is shown in Table 3.

TABLE 3. Frequency change response in Area 1 (Δf_1) with load change 0.1 p.u.

	PID	PID CES	PID CES PSO	PID CES QPSO
Overshoot (p.u)	-0.00358	-0.00197	-0.00183	-0.00207
Settling time (sec)	21	19	11.2	11.2

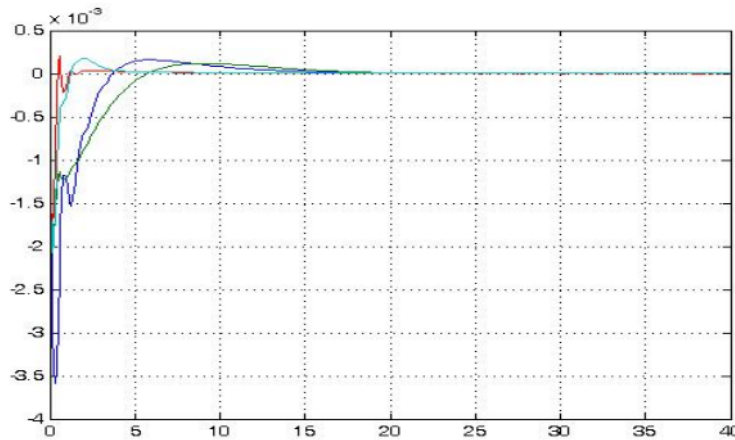

FIGURE 5. Frequency change response in Area 1 (Δf_1) with load change 0.1 p.u.

The frequency response of Area 2 (Δf_2) is shown in Fig. 6. It can be seen that a system with a PID controller has an overshoot of -0.000368 p.u. and a settling time of 30.5 seconds. Then after installing the PID and CES, the overshoot decreases to -0.000291 p.u. while the settling time was 36.5 seconds. While optimization using PSO, the overshoot decreases to -0.0001 p.u. and the settling time became 24.5 seconds. And then, optimization using QPSO, the overshoot increases to 0.00088 p.u. and the settling time became 24.5 seconds.

For more details, the overshoot and settling time of the Area 2 frequency response are given in Table 4.

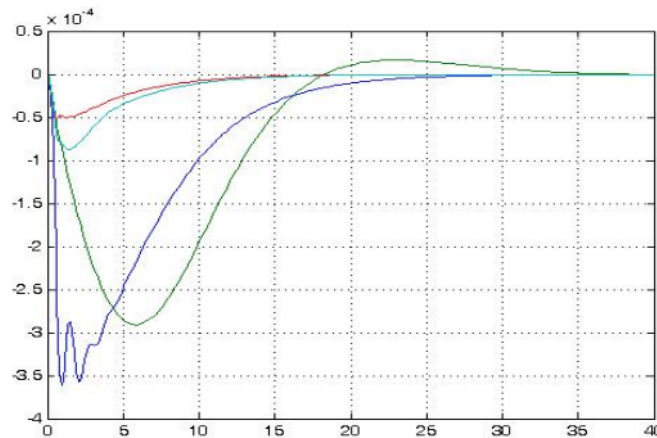

FIGURE 6. Frequency change response in Area 2 (Δf_2) with load change 0.1 p.u.

TABLE 4. The response data for the change in frequency Area 2 (Δf_1) with changes in load 0.1 p.u

	PID	PID CES	PID CES PSO	PID CES QPSO
Overshoot (p.u)	-0.000368	-0.000291	-0.00053	-0.00088
Settling time (sec)	30.5	36.5	24.5	24.5

Power between Area 1 and Area 2 (P_{tie}) is shown in Fig. 7. From Fig. 7, the system with a PID controller has an overshoot of -0.00585 p.u. and a settling time of 31 seconds. Then after installing the PID and CES, the overshoot was reduced to -0.0057 p.u. while the settling time was 40 seconds. While optimization using PSO, the overshoot was reduced to -0.00092 p.u. and the settling time became 21 seconds. And then, optimization using QPSO, the overshoot increases to -0.00165 p.u. and the settling time became 21 seconds. For more details, the overshoot and settling time between areas of power (P_{tie}) can be seen in Table 5.

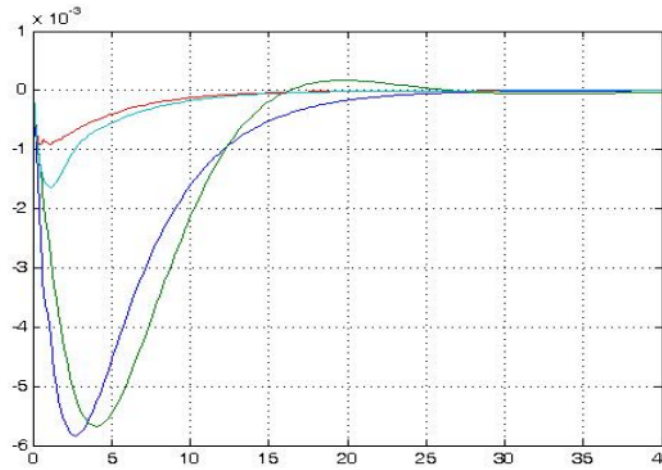

FIGURE 7. Power response between areas (P_{tie}) with a load change of 0.1 p.u.

TABLE 5. Power response data between areas (P_{tie}) with a load change of 0.1 p.u

	PID	PID CES	PID CES PSO	PID CES QPSO
Overshoot (p.u)	-0.00585	-0.0057	-0.00092	-0.00165
Settling time (sec)	31	40	21	21

From the simulation results, it can be seen that systems using PID and CES controllers optimized with PSO have the lowest overshoot responses even when compared to QPSO. However, they both have the same settling time. However, in more detail, the results of the system response with PID and CES optimized with PSO have ripples, while the simulation results with QPSO produce a smooth system response. From several simulations, the Optimization with PSO produces lower overshoot values than the optimization with QPSO, but it produces ripple. While the system response to the optimization with QPSO is softer and obtains several faster settling times and has no ripple. Finally, these two types of optimization techniques have their own advantages and disadvantages in the application of PID and CES optimization on Two area interconnected power system.

CONCLUSION

The application of the PSO and QPSO methods to obtain the values of PID and CES in Two area interconnected power system can reduce the oscillations of Area 1 (Δf_1) frequency, Area 2 (Δf_2) frequency and inter-area power (P_{tie}) better than systems without PID CES and PID CES system with manual setting of constant values. The PSO and QPSO PID CES optimization methods result in a faster settling time and lower overshoot. Optimization with PSO

resulted in an overshoot and settling time of -0.00183 p.u. and 11.2 seconds in Area 1, -0.00053 p.u. and 24.5 seconds in Area 2 and -0.00092 p.u. and 21 seconds in Inter area power. Meanwhile, optimization with QPSO results in an overshoot and settling time of -0.00207 p.u. and 11.2 seconds in Area 1, -0.00088 p.u. and 24.5 seconds in Area 2 and -0.00165 p.u. and 21 seconds in Inter area power. The final results show that in case of Two area interconnected power system, PSO can reduce oscillations better than QPSO, but it produces ripple. Meanwhile, the QPSO optimized system produces smoother and no ripple responses.

REFERENCES

- [1] M. Ruswandi, *Int. J. Eng. Manuf.* **8**, 1 (2018).
- [2] S.C. Tripathy, *Energy Convers. Manag.* **38**, 8 (1997).
- [3] L. Chunyan and C. Xiangyi, in *5th IEEE Conf. Ind. Electron. Appl.* (2010), pp. 808–813.
- [4] S.C. S. Tripathy, *IEEE Trans. Energy Convers.* **12**, 187 (1997).
- [5] S. Banerjee, J.K. Chatterjee, and S.C. Tripathy, *IEEE Trans. Energy Convers.* **5**, 46 (1990).
- [6] I. Ngamroo, S. Dechanupaprittha, K. Hongesombut, Y. Mitani, A. Kunakorn, A.L. Power, and S. Model, in *Int. Power Eng. Conf.* (2005), pp. 1–6.
- [7] V. Mukherjee and S.P. Ghoshal, *Electr. Power Syst. Res.* **79**, 282 (2009).
- [8] A. Milani and M. B., in *AIP Conf. Proc.* (2009), p. 1159.
- [9] P.P.S. Saputra, *J. Adv. Res. Electr. Eng.* **2**, 8 (2018).
- [10] K. Jagatheesan, B. Anand, and M. Omar, *Int. J. Electr. Eng. Informatics* **7**, 541 (2015).
- [11] H. Saadat, *Power System Analysis*, 2nd ed. (McGraw-Hill Inc., 2004).
- [12] P. Kundur, *Power System Stability and Control* (McGraw-Hill Inc., 1994).
- [13] S.C. Tripathy and I.P. Mishra., *Energy Convers. Manag.* **37**, 178 (1996).
- [14] J. Kennedy and R. Eberhart, in *IEEE Conf. Neural Netw.* (1995), pp. 1942–1948.
- [15] J. Jie, J. Zeng, C. Han, and Q. Wang, *Appl. Math. Comput.* **205**, 861 (2008).
- [16] A.T. Al-awami and M.A. Abido, *Int. J. Electr. Power Energy Syst.* **29**, 251 (2007).
- [17] J. Zhu, *Optimization of Power System Operation* (IEEE press series on Power Engineering, OPSSO, John Wiley & Sons Inc, America, 2009).
- [18] S. Lu, C. Sun, and Z. Lu, *Energy Convers. Manag.* **51**, 561 (2010).
- [19] S. Coelho, *Expert Syst. Appl.* **37**, 1676 (2010).
- [20] S.N. Omkar, R. Khandelwal, T.V.S. Ananth, G.N. Naik, and S. Gopalakrishnan, *Expert Syst. Appl.* **36**, 11312 (2009).
- [21] P.P.S. Saputra, in *IEEE 11th Int. Conf. Appl. Sci. Technol.* (2020).

Optimization of PID - Capacitive Energy Storage for Load Frequency Control in Two Area Interconnected Power System Using Quantum Behaved PSO

ORIGINALITY REPORT

21 %
SIMILARITY INDEX

10 %
INTERNET SOURCES

19 %
PUBLICATIONS

%
STUDENT PAPERS

PRIMARY SOURCES

1 Qing Li, Peng Cheng, Xiangjun Hao, Jinping Zhang. "Stator current vector control strategy of doubly fed induction generator using proportional-resonant regulators", The Journal of Engineering, 2009 **2** %
Publication

2 Sumathi, S, L Kumar, and Surekha P. "Voltage and Frequency Control in Power Systems", Computational Intelligence Paradigms for Optimization Problems Using MATLAB®/SIMULINK®, 2015. **2** %
Publication

3 Siddhartha Deb Roy, Sanjoy Debbarma. "Inertia Emulation Using Battery Management System in a Low Inertia Grid with HVDC Links", 2018 2nd International Conference on Power, Energy and Environment: Towards Smart Technology (ICEPE), 2018 **2** %
Publication

4	Xiejing Ling. "Economic-environmental dispatch based on multi-objective quantum-behaved particle swarm optimization", AIP Publishing, 2017 Publication	1 %
5	Zhang Min, Zhang Wenjun, Li Xi, Guo Fucheng. "Passive localization method by multiple observers using ambiguous PDOA", 2022 International Symposium on Sensing and Instrumentation in 5G and IoT Era (ISSI), 2022 Publication	1 %
6	repository.ukitoraja.ac.id Internet Source	1 %
7	eprints.umg.ac.id Internet Source	1 %
8	jurnal.unmer.ac.id Internet Source	1 %
9	Darya Khan, Jamshed Ahmed Ansari, Shahid Aziz Khan, Usama Abrar. "Power Optimization Control Scheme for Doubly Fed Induction Generator Used in Wind Turbine Generators", Inventions, 2020 Publication	1 %
10	A M S Yunus, M R Djalal, Y S Akil. "SMIB stability enhancement using capacitive energy storage and PID based on ant colony	1 %

optimization", IOP Conference Series: Earth and Environmental Science, 2020

Publication

11	mevjournal.com Internet Source	1 %
12	oaji.net Internet Source	1 %
13	www.mdpi.com Internet Source	1 %
14	"Advances in Natural Computation", Springer Science and Business Media LLC, 2005 Publication	1 %
15	rsujnet.org Internet Source	1 %
16	Mukherjee, V.. "Application of capacitive energy storage for transient performance improvement of power system", Electric Power Systems Research, 200902 Publication	1 %
17	R.J. Abraham, D. Das, A. Patra. "Effect of capacitive energy storage on automatic generation control", 2005 International Power Engineering Conference, 2005 Publication	1 %
18	Ismayil, Chathoth, Ramdas Sreerama Kumar, and Thiruthimana Krishnan Sindhu. "Optimal	1 %

fractional order PID controller for automatic generation control of two-area power systems : FOPID CONTROLLER FOR AGC OF MULTI-AREA POWER SYSTEMS", International Transactions on Electrical Energy Systems, 2014.

Publication

19

S.C. Tripathy, I.P. Mishra. "Dynamic performance of wind-diesel power system with capacitive energy storage", Energy Conversion and Management, 1996

Publication

20

Tao Ling, Zhi-Hui Zhan, Yong-Xing Wang, Zi-Jia Wang, Wei-Jie Yu, Jun Zhang. "Competitive Swarm Optimizer with Dynamic Grouping for Large Scale Optimization", 2018 IEEE Congress on Evolutionary Computation (CEC), 2018

Publication

21

core.ac.uk

Internet Source

22

Umut Ozkaya, Levent Seyfi. "A comparative study on parameters of leaf-shaped patch antenna using hybrid artificial intelligence network models", Neural Computing and Applications, 2016

Publication

1 %

1 %

1 %

1 %

Exclude quotes Off

Exclude matches < 1%

Exclude bibliography On